



“2014 ISSST”, 2014 International Symposium on Safety Science and Technology

Research on explosion characteristics of sulfur dust and risk control of the explosion

YU Yanqiu^{a,b}, FAN Jianchun^{a*}

^aCollege of Mechanical and Transportation Engineering, China University of Petroleum, 18 Fuxue Road, Beijing 102249, China

^bSinopec Dazhou Natural Gas Purification Co., Ltd., Dazhou 635000, Sichuan, China

Abstract

As dust explosion is a major risk factor threatening the safety of sulfur production, evaluating and controlling the hazards of sulfur dust produced in the wet process are very important. Several characteristic parameters including minimum ignition temperature, minimum ignition energy, lower explosive limit, maximum explosion pressure, explosion index, limit oxygen concentration of sulfur dust were determined and investigated by the experimental device such as hot plate, Godbert-Greenwald furnace, Hartmann tube, 20L spherical container of explosive testing. The experimental results indicated the influence rules of particle size, water content and concentration on the explosion characteristics of sulfur dust. The results showed that sulfur dust could be lighted easily and had high explosibility. The explosion risk and strength of sulfur dust decreased with the increase of the particle size. The minimum ignition energy and the minimum ignition temperature increased as the water content increased. The maximum explosion pressure and the explosion index rose at first and went down latter as the dust concentration increases. Prevention and control measures of sulfur dust explosion, from two aspects of building control and process control, were proposed for production, storage and transportation process of sulfur produced in the wet process.

© 2014 The Authors. Published by Elsevier Ltd. This is an open access article under the CC BY-NC-ND license (<http://creativecommons.org/licenses/by-nc-nd/3.0/>).

Peer-review under responsibility of scientific committee of Beijing Institute of Technology

Keywords: Sulfur dust; Explosion characteristic parameters; Influence law; Prevention and control measures

1. Introduction

With the development of large-scale natural gas fields in Puguang region, the scale of production and storage of sulfur increases rapidly. Instead of traditional dry molding process, a wet molding process has been used to produce

* Corresponding author. Tel.: +86-135-0110-3910.

E-mail address: fjc688@126.com

sulfur in the natural gas treating plant in Puguang. By comparison, there was less dust in the production of sulfur by wet-process. But, there are still high risks of combustion and explosion which have been paid great attention to.

Over the last several decades, a large amount of research on prevention and mitigation of sulfur dust explosion, which mainly focused on the sulfur produced in the dry molding process, has been done through simple dogmatic design methods^[1-8]. However, fundamental knowledge for understanding practical sulfur dust explosion is not available. Advanced numerical models will play an increasingly important role in solving practical design problems.

The relationships between the minimum ignition temperature (MIT) and dust particle size of coal, metals and several plastics have been studied by Cassel and Liebman^[9], and an inverse relationship has been found. A similar observation has been revealed by Du and Annamalai^[10] through researching the transient ignition of isolated coal particles. The ignition temperatures of coal particles have been measured and predicted by Chen et al.^[11], Bandyopadhyay and Bhaduri^[12].

In the work of Cassel and Liebman^[13], the importance of concentration and reaction mechanisms of dust clouds ignition was proved. It was found that a dispersed cloud of particles exhibited a lower critical ambient temperature for ignition than single-particle of the same material. The reason about the reduction of heat losses from dust cloud to the surrounding environment was identified. The MIT of commercial samples of iron sulphide dusts was measured by Amyotte^[14] using the BAM oven. It was revealed that the MIT declined with a decrease in the mass mean particle diameter. The minimum ignition energies (MIE) of dust clouds was tested by Eckhoff and Randeberg^[15] employing a new spark generator which can produce synchronised sparks within 1 mJ.

There were few researches about the sulfur produced in the wet molding process. The characteristics of sulfur produced in the dry molding process were not absolutely applicable for the wet one. And it is lack of theoretical basis to develop prevention measures of combustion and explosion of sulfur dust produced in a wet molding process.

This paper is aimed to explain the explosion mechanism of sulfur dust, study the explosion characteristics, and provide theoretical basis for the field production in Puguang region to prevent sulfur dust from explosion.

2. Experiments

2.1. Experimental materials

Experimental samples were standard sulfur dust with particle size of $< 75\mu\text{m}$, sulfur dust with particle size of 1.4–1.7 mm, and original sulfur dust with particle size of 2–6 mm.

2.2. Measurement of minimum ignition temperature of sulfur dust layer (MIT-L)

The measurement of minimum ignition temperature of sulfur dust layer was carried out at a hot plate (shown in Fig. 1), which was heated by heating wires. The minimum temperature of the hot surface was detected as the specific thickness of the dust layer fires. Thermocouples were used to control and measured the temperatures of hot plate. The dust layer with specific thickness was put on a supporting ring of the hot plate, and a thermocouple was equipped into the dust layer in order to record the temperature.

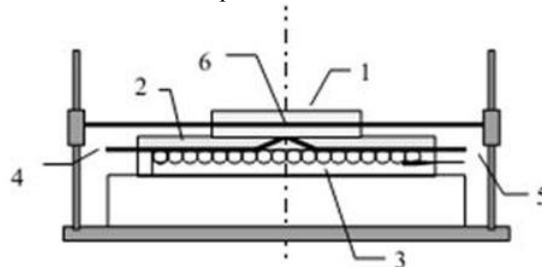

1-dust filling ring; 2-hot plate; 3-heater ; 4,5,6-thermocouples

Fig. 1. Measurement device for minimum ignition temperature of sulfur dust layer.

2.3. Measurement of minimum ignition temperature of sulfur dust cloud (MIT-C)

The MIT-C was detected at a Godbert-Greenwald furnace (shown in Fig. 2). The main part was a quartz furnace tube with an open bottom and heating wires around the tube. The experiments indicated that temperature distribution of the furnace tube was homogeneous. During every experiment, compressed air would be introduced into the quartz furnace tube to form a dust cloud. The fire was observed through a window in the furnace. The explosion temperature could be confirmed and recorded according to the temperature-time records.

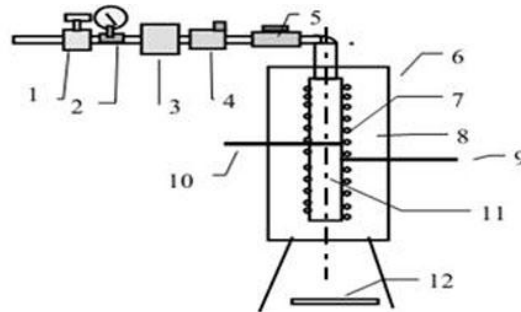

1-needle valve; 2-pressure gage; 3-dust chamber; 4-solenoid valve; 5-dust chamber; 6-furnace shell; 7-resistance wire; 8-thermal insulation material; 9, 10-thermocouples; 11-quartz tube furnace; 12-reflector

Fig. 2. Measurement device for minimum ignition temperature of sulfur dust cloud.

2.4. Measurement of minimum ignition energy of sulfur dust cloud (MIE)

A Hartmann tube explosive device (shown in Fig. 3) was adopted to measure the minimum ignition energy of sulfur dust cloud. It was ignited by capacitance discharge. A double-electrode system and a movable electrode were used by discharge circuits to trigger spark auxiliary. Two movable electrodes were fixed in the Hartmann tube with top open. One electrode was connected with a screw micrometer. One end of the other electrode was connected with a push rod through teflon, which was controlled by a double-acting pneumatic piston (diameter 35 mm, operating pressure 600 kPa, operating stroke 10 mm), and the other end was connected with a capacitor with 26PF - 311 μ F. When the high voltage generator broke from the capacitor circuit, the compressed air was introduced to form clouds. Certain time later, the high voltage electrode was pushed to the set position, and electric spark was produced through the capacitor discharge.

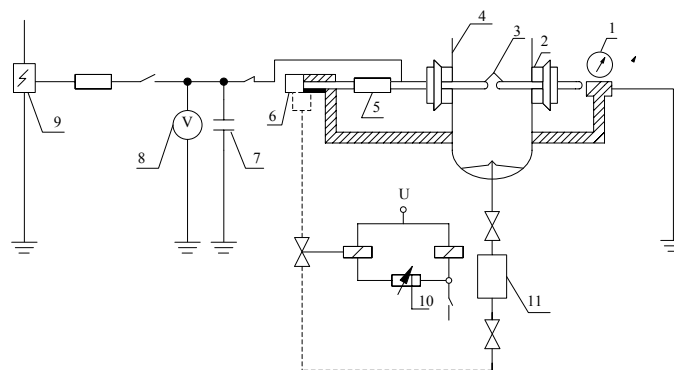

1-screw micrometer; 2-fixed seat; 3-electrode; 4-Hartmann tube; 5-Teflon insulation; 6-double-acting pneumatic piston; 7-capacitor; 8-voltmeter; 9-high pressure generator; 10-relay; 11-air vessel

Fig. 3. Measurement device for minimum ignition energy of sulfur dust cloud.

2.5. Measurement of maximum explosion pressure (P_{max}) and explosion index (K_{max})

A spherical explosion test device with a volume of 20 L was used for measuring the maximum explosion pressure and explosion index, the test device is shown in Fig. 4. It was equipped with a stainless steel spherical container, a dust scatter and an ignition system. The temperature of container was controlled by the circulating water in an outside jacket. The dust sample was put in a 600 ml storage tank, and the pressure was maintained at 2 MPa. Dust was scattered by high pressure gas to the spherical container as the valve was opened. After 60ms, the dust would be detonated by a 10 kJ energy ignition head which was fixed in the center of the container, and the pressure of the container was recorded by a pressure sensor.

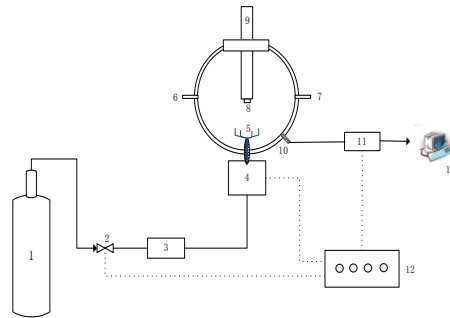

1-compressed air; 2-solenoid valve; 3-dust chamber; 4-two-phase valve; 5-scatter nozzle; 6-air inlet; 7-vacuum outlet; 8-ignition head 9-electrode; 10-pressure sensor; 11-data collection; 12-controller; 13-computer

Fig. 4. Spherical measurement device for maximum explosion pressure and index of sulfur dust cloud.

3. Results and discussion

3.1. Sulfur dust explosion mechanism

Sulfur dust was prone to burning or exploding, essentially due to the reducibility of Sulfur element. This redox process was significantly affected by both the reaction kinetics and the gas-solid two-phase flow kinetics.

Sulfur dust particle gained energy from the ignition source through the heat conduction and thermal radiation. Then the surface temperature rose sharply and formed a decomposition gas which was flammable and mixed with the air. Dust particle was melted and then gasified from the surface to the core. Simultaneously, tiny spark, which acted an ignition source, was broke out by the particle. As a result, the combustion was accelerated as the pressure increased. Flame propagation and sulfur dust combustion extended, which made the pressure sharp rose and led to an explosion at last. This kind of process cycled until the sulfur dust burnt out and the reaction terminated. The mechanism of sulfur dust explosion is shown in Fig. 5.

The oxidation reaction of sulfur dust occurred mainly in the gas phase, and heat release rate of oxidation was restricted by mass transfer. That is to say, the oxygen also diffused from the gas phase to the particle surface while the oxidate diffused from the particle surface to the gas phase. The diffusion rate was much slower than the oxidation rate, which meant the control steps.

3.2. Characteristics of sulfur dust explosion

Although sulfur dust explosion can be treated as a kind of gas explosion, some characteristics of combustion and explosion of sulfur dust is special. Firstly, sulfur combustion reaction lasts for a long time, which results in that large amount of energy is released and strong destructive power is emitted. The induction period of sulfur dust combustion reaction can last for tens of seconds. At the same time, the energy density of the explosion is much higher. The temperature can rise to 2000–3000 °C and the maximum explosion pressure can reach 700 kPa. Especially, the dust particles burns and becomes ignition source resulting in other fuel burning, which aggravates the explosion damage.

Secondly, the rate of pressure rises faster than flame. Sulfur dust explosion begins with blast pressure, and the flame appears 0.1s to 0.2s later. Under the normal temperature and pressure, the initial rate of flame propagation is between 2m/s and 3m/s. Due to burning inflation, the pressure rises rapidly, which accelerates the flame propagation up to 300m/s. Furthermore, the “secondary explosion” happens during the sulfur dust explosion. Once sulfur dust explosion happens, the blasting wind hikes up ambient dust to form a new mixture, of which the concentration is much higher than the first explosion. In the explosion center, negative pressure zone forms instantaneously, and the fresh air flows to the explosion center which is composed of the new dust and reconstituted explosive dust. Consequently, the second and third explosions happen. The pressure during subsequent explosions is higher, and destructiveness is more serious. Compared to the normal gas explosion, toxic gas SO₂ is produced by sulfur dust explosion, which is a poisoning hazard.

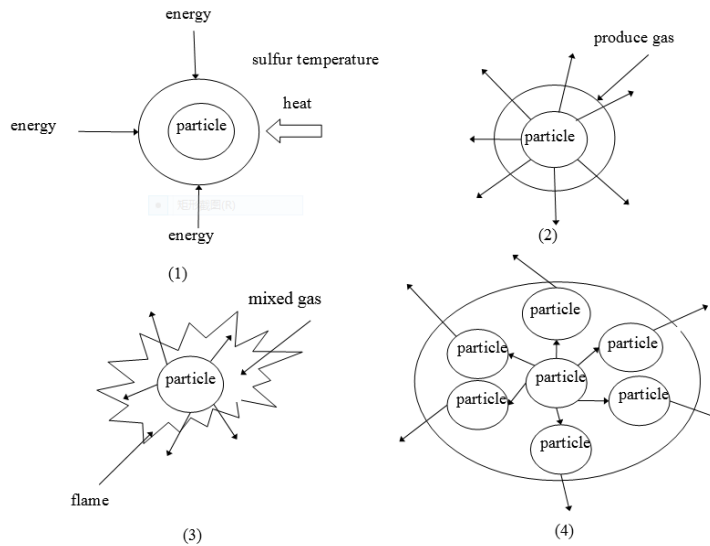

Fig. 5. Explosion mechanism of sulfur dust.

3.3. Characteristics parameters of sulfur dust explosion

Sulfur explosion hazard is mainly represented by difficulty degree and blasting strength, which are the important basic parameters for explosion prevention and protection design of industrial process. As reviewed by Essenhigh et al.^[16], dust-ignition studies had fell into two categories: single particles and dust clouds. In this paper, six parameters including MIT-L, MIT-C, MIE, maximum explosion pressure and explosion index, lower explosive limit, and limit oxygen concentration were determined through experiments.

3.3.1. Minimum ignition temperature of sulfur dust layer (MIT-L)

MIT-L represents the ignition sensitivity of cumulate dust. On the surface of equipment and pipelines in the workshop, there often is deposited a layer of combustible dust. The dust oxidation rate would be accelerated while the surface or environmental temperature increased. With the heat constant accumulation, the spontaneous combustion could happen. Usually, it was the ignition source of dust explosion rather than the fire of dust layer resulted in explosion. MIT-L results are measured and shown in Table 1.

Table 1. Minimum ignition temperature of sulfur dust layer

Size	< 75 μm	1.4–1.7mm	2–6 mm
Minimum ignition temperature /°C	250	250	250

3.3.2. Minimum ignition temperature of sulfur dust cloud (MIT-C)

When the dust cloud (a mixture of dust and air) is heated, the MIT-C is the minimum heating temperature (environment temperature) of ignition. If sulfur dust exposed to a heat source with enough high temperature, it could be on fire or explosion, and the fire of dust cloud was the initial stage of explosion caused by energy transfer. Once the dust cloud fires, whose concentration was within the explosion limit, the dust explosion happened. MIT-C results are shown in Table 2. It is found that the MIT-C of sulfur dust with a size of less than 75 μm was 210 $^{\circ}\text{C}$, which was much lower than those of other dusts such as coal, corn starch and magnesium, typically 400- 500 $^{\circ}\text{C}$. So sulfur dust had higher explosion sensitivity compared to other dusts.

Table 2. Minimum ignition temperature of sulfur dust cloud.

Size	<75 μm	1.4–1.7 mm	2–6 mm
Minimum ignition temperature / $^{\circ}\text{C}$	210	480	No suspension

3.3.3. Minimum ignition energy of sulfur dust cloud (MIE)

MIE represents the ignition sensitive degree of dust and can be applied to evaluate the risk of thermal surface ignition source such as mechanical spark and electrostatic discharge.

MIE can be calculated by testing the voltage of electrode and current waveform, or making integral of the power curve to obtain the energy of spark. The integral expression is:

$$E = \int_0^t (UI - I^2 R) dt \quad (1)$$

In the equation, E is MIE of sulfur dust, U is the voltage of electrode, I is the current value, R is the resistor value, and t is the test time.

Test results are shown in Table 3. It can be seen from Table 3 that the MIE of sulfur dust with particle size <75 μm was 0.38 mJ, which was much lower than that of other common dust suggesting a higher explosion sensitivity. When the size was between 1.4mm and 1.7mm, the MIE is higher than 13J. The sulfur dust generally could be ignited only by flames that seemed more safely.

Table 3. Minimum ignition energy of sulfur dust cloud

Size	<75 μm	1.4–1.7 mm	2–6 mm
Minimum ignition energy	0.38 mJ	> 13 J	No suspension

3.3.4. Maximum explosion pressure (P_{max}) and explosion index (K_{max})

The P_{max} , K_{max} , and rise rate of pressure are important parameters for describing the explosion ferocity degree, designing the structural strength and explosion-proof pressure relief area. The P_{max} is the biggest pressure of value in the closed device under the best concentration condition of sulfur dust. The explosion index, K_{max} refers to the maximum pressure rise in the closed device under the best concentration condition of sulfur dust per unit time. K_{max} can be obtained from eq (2).

$$K_{\text{max}} = \left(\frac{dP}{dt} \right)_{\text{max}} V^{1/2} \quad (2)$$

In the equation, (dP/dt) is the maximum rise rate of explosion pressure, V is the capacity of test device.

The explosion pressure-time curve of different dust concentration was measured at the device illustrated in Fig. 6 and used to obtain the P_{max} and the K_{max} . The results are shown in Table 4. It can be seen from Table 4 that the P_{max} of sulfur dust was lower than that of light metal (such as magnesium, P_{max} is 0.9 MPa), grain and plastic dust (0.7–

0.8 MPa). Meanwhile, the K_{max} was found 20–30 $MPa \cdot m \cdot s^{-1}$, which was higher than that of grain and plastic dust (10–15 $MPa \cdot m \cdot s^{-1}$), but slightly lower than that of light metal (generally was above 30 $MPa \cdot m \cdot s^{-1}$).

3.3.5. Lower explosive limit of sulfur dust cloud (LEL)

The lower explosive limit of sulfur dust cloud (LEL) is the minimum concentration of dust cloud just to burn automatically and continuously under the specific energy, and it is the minimum concentration of sulfur dust explosion. During the industrial production process, effective measures should be taken to keep the concentration below LEL as to prevent explosion. A spherical explosion test device with volume 20 L was used to measure the LEL. Operating procedures was same to that of P_{max} measurement. The explosion was monitored by the explosion pressure, which was 0.05 MPa higher than the explosion pressure of ignition head itself. The dust concentration reduced gradually until the explosion terminated.

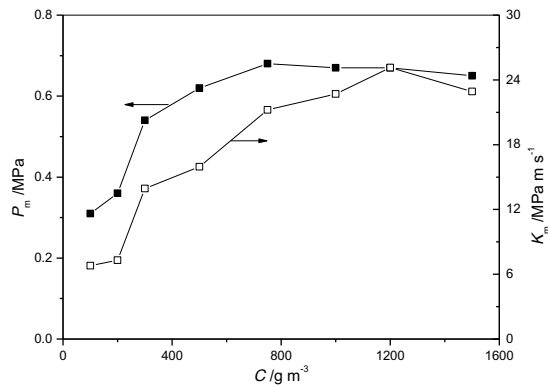

Fig. 6. Influence of dust concentration on the explosion pressure, P_m and explosion index, K_m

Table 4. Maximum explosion pressure and explosion index of sulfur dust.

Size	<75 μm	1.4–1.7 mm	2–6 mm
Maximum explosion pressure /MPa	0.68	0.56	No suspension
Explosion index / $MPa \cdot m \cdot s^{-1}$	25.13	10.76	No suspension

Test results are shown in Table 5. And it can be seen that LEL of sulfur dust cloud with particle size less than 75 μm was 30 g/m^3 , which was very low. Sulfur dust was easy to form explosive dust cloud and dust concentrations should be strictly controlled in the production process.

Table 5. Lower explosive limit of sulfur dust cloud.

Size	<75 μm	1.4–1.7 mm	2–6 mm
lower explosive limit / $g \cdot m^{-3}$	20–30*	100–150	No suspension

* 20 g/m^3 : without explosibility; 30 g/m^3 : with explosibility.

3.3.6. Maximum oxygen content

Dust cloud explosion will not happen no matter how dust concentration changes if the oxygen content of dust cloud declines to certain value. Test results are shown in Table 6.

Table 6. Maximum oxygen content of sulfur dust cloud.

Size	<75 μm	1.4–1.7 mm	2–6 mm
Maximum oxygen content /%	9	-	No suspension

3.4. Influences of several factors on the explosion characteristics of sulfur dust

The sulfur dust samples with different properties show different explosion characteristics. And same sulfur dust samples exhibit very different explosion characteristics under different conditions. Main factors including particle size, humidity, and dust concentration have different influences on the explosion characteristics of sulfur dust.

3.4.1. Particle size

According to the explosion mechanism of sulfur dust, the smaller the particle size of sulfur dust is, the more volatiles are released. As a result, the explosion pressure of sulfur dust was higher and the explosive power was greater because of the sulfur dust with smaller size. The explosion characteristic parameters for sulfur dust with different particle sizes were measured and the results are listed in Table 7.

From Table 7, it can be seen that, with the increase of particle size, the maximum explosion pressure and explosion index decreased while the ignition energy and ignition temperature decreased. It indicated that the explosion risk and power of sulfur dust decreased as the particle size increased. Especially, the effect of the particle size on the ignition energy and ignition temperature was significant. The ignition energy and ignition temperature of sulfur dust with particle size larger than 150 μm were higher than 13 J and 400 $^{\circ}\text{C}$, which were almost impossible to reach the ignition source except flame or hot surfaces in the industrial production. It was, thus, not easy to be ignited in the industrial process because of the high ignition energy and ignition temperature, although the sulfur dust with particle size more than 150 μm was explosible.

Table 7. Explosion characteristic parameters of sulfur dust with different sizes.

Size range / μm	Mean size / μm	Ignition energy /mJ	Minimum ignition temperature / $^{\circ}\text{C}$	Maximum explosion pressure /MPa	Explosion index / $\text{MPa}\cdot\text{m}\cdot\text{s}^{-1}$
< 75	35	0.38	210	0.68	25.13
< 150	75	3.4	230	0.63	20.43
150 ~ 420	285	$>1.3\times 10^4$	400	0.59	16.87
1400 ~ 1680	1540	$>1.3\times 10^4$	490	0.56	10.76

3.4.2. Water content

There is a significant relationship between the explosibility of sulfur dust and its water content. The sulfur dust sample with size less than 150 μm was used to study the effects of humidity on the ignition energy and minimum ignition temperature. The results are shown in Table 8 and Fig. 7. It can be seen that the water content of sulfur dust had a great effect on the minimum ignition energy. The minimum ignition energy increased slowly while the water content was less than 3%. However a rapid increase in minimum ignition energy could be found while the water content was larger than 5%. As for the water contents of about 4% and 5%, the energy was about 10 mJ, which indicated the low ignition risk of electrostatic and mechanical spark, about 25 mJ, which was nearly similar to that of corn starch. As the humidity was larger than 10%, the minimum ignition energy reached to 50 mJ, suggesting that the sulfur dust was safe relatively. Under that condition, coalescence of sulfur dust could be observed because there was too much moisture to be scattered to form cloud. So, it was an effective measure to spray water to prevent sulfur dust from forming explosible cloud during industry production. Furthermore, the minimum ignition temperature of dust cloud rose almost linearly as the humidity increased.

Table 8. Ignition energy and minimum ignition temperature of sulfur dust with various water contents

Water content /%	Ignition energy /mJ	Minimum ignition temperature / $^{\circ}\text{C}$
0.7	4.8	210
3.2	8.2	220
5.4	25	230
8.5	61	250
14.6	68	265

3.4.3. Dust concentration

The relationships between dust concentration C , the P_{max} and maximum explosion pressure rise rate (R_{max}) are determined by using the spherical explosion test device with volume of 20 L (shown in Fig. 8). The results showed that both the P_{max} and R_{max} increased along with the increase of dust concentration. P_{max} and R_{max} both reached the biggest values while the dust concentration reached a certain value. Then, they declined with the further increase of dust concentration. The P_{max} and R_{max} increased rapidly with the dust concentration in 200–300g/m³ while those increased gently in other dust concentration range. The dust concentration should be controlled at 200g/m³ or less in the production of sulfur. When the dust concentration was 1500g/m³, explosion pressure and explosion index remained high which showed that sulfur dust with a higher explosion limit was easy to form explosive dust cloud.

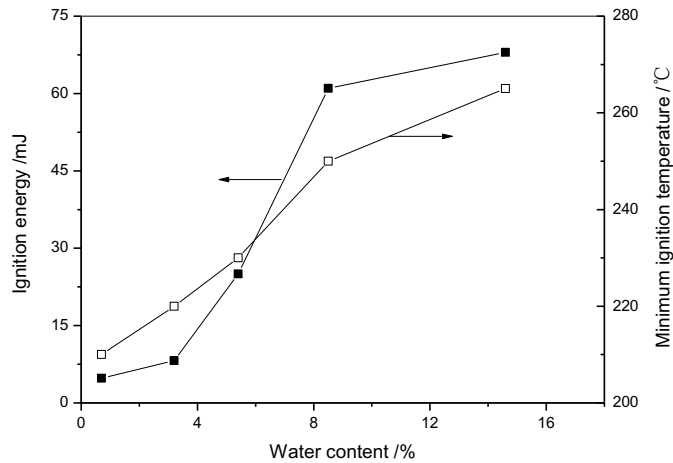

Fig. 7. Influence of water content on the ignition energy and minimum ignition temperature of sulfur dust.

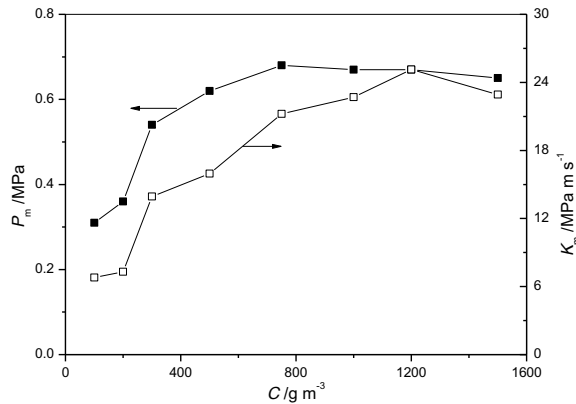

Fig. 8. Influence of dust concentration on the explosion pressure, P_m and explosion index, K_m .

3.5. Measures for the prevention and control of sulfur dust explosion

It is very important that the explosion risk prevention is established to ensure effective explosion protection of process plant even in small and medium size plants.

Two main aspects should be considered in an effective sulfur explosion protection system. One is how to decrease the risk of fire, and the other is how to enhance the measures for rescuing fire and explosion. Especially, safety techniques in specific process should be developed to eliminate the unsafe factors in sulfur storage and transportation process.

3.5.1. Structure of buildings

Open or outdoors types of buildings are best for sulfur production and storage. And the location of building should be considered adequately to prevent other work sites and buildings from being threatened when the explosion happens. The warehouse of sulfur should be made of incombustible materials, and should be kept cool, ventilated, dry and adiabatic. In addition, sulfur should be stored individually far from acid and antioxidant^[17]. All parts should be designed according to the explosion proof demands in order to ensure the building can stand up to the maximum explosion pressure even if an explosion happens. Meanwhile, the building components should meet the requirements of refractory.

3.5.2 . Control measures for production process

(1) Control measures for combustible

Take measures to prevent sulfur from mixing with other combustible substance, and prevent sulfur dust and air from forming the explosive mixture.

(a) Ventilation and dust removal system

The concentration of sulfur dust can be reduced through the effective ventilation and dust removal measures, and kept below the lower explosive limit of explosion concentration. It is crucial to layout and design the ventilation pipe system reasonably to keep the optimum wind speed of 1.5-2 m/s. Dust removal device such as dust removal blower and separator can be adopted to catch the suspended dust in the wind.

(b) Wet operation

The explosion risk can be reduced by increasing the humidity and elevating the viscosity of sulfur dust. Sulfur dust is hard to suspend in the air because of the coalescence of it. When the wet dust is heated up, the moisture will evaporate firstly. Meanwhile, the reaction activity of dust mixture is reduces by the mixing of vapour and pyrolysis gas. Mist spray is the main control measure to decrease the suspended dust in the wind by purifying water curtain, transfer points spray or ventilation air system spray etc.

(2) Eliminating ignition source

(a) Preventing friction, strike, and thermogenesis

The open flame operations such as welding and cutting are strictly prohibited in the dust environment. The nonferrous metal tools should be used to prevent the strike spark. Check and maintain equipment regularly to prevent machinery components loose. Pay attention to rotating parts of lubrication machine, and check the bearing temperature regularly to prevent overheating. Keep the feed flow uniform to prevent the friction heating caused by feed break. Make sure the surface temperature of sulfur conveying equipment below the temperature of sulfur smoldering. Pay attention to the temperature changes of the internal stack and inside of warehouse to prevent the heat smolder in the sulfur stacking.

(b) Preventing electric spark and electrostatic discharge

Electrical equipment should meet the requirement of explosion proof, and the whole electric circuit should be checked and maintained regularly. For the equipment which can generate combustible dust, the grounding device must be fixed on them. The anti-static material can be selected because increasing humidity is very effective to prevent the accumulation of static electricity. In addition, the corresponding lightning protection device must be set up.

(3) Necessary fire extinguishment and explosion proof facilities

(a) Automatic alarm system

Automatic fire alarm and sulfur dust concentration detection system must be set up. And it is very important to monitor the source of sulfur dust.

(b) Reasonable fire extinguishment facilities

Sulfur fire can be put out with water, sand, foam, and powder extinguisher. Meanwhile, mist spray device is suggested in order to prevent splash and even explosion, which is caused by water flow sprayed to melt sulfur directly during fire extinguishment.

(c) Inert gas shielding

When the sulfur is treated in a closed space, inert gas such as nitrogen and carbon dioxide should be injected in order to reduce the oxygen content of mixture gas to decrease the risk of sulfur dust explosion. The minimum oxygen content should meet the requirement of inert gas protection. Generally, the lower limit is 12% for carbon dioxide and 9.3% for nitrogen.

d) Explosion pressure relief device

A certain pressure relief unit should be considered in the design of bulk sulfur warehouse. The pressure reduced plate can be set up in the intensively protected or high-risk equipment to reduce the hazard of explosion pressure.

4. Conclusions

(1) Sulfur dust could be lighted easily. The ignition energy and minimum ignition temperature were very low, and the prevention of electrostatic and mechanical spark must be considered during the production process of sulfur dust with particle size below 0.5 mm.

(2) The explosibility of sulfur dust was high and it was easy to form explosive dust cloud. The P_{max} was medium and the LEL was low. Sulfur dust could be classified as the St2 explosive dust, as the explosion index of it was high.

(3) The explosion risk and strength of sulfur dust decreased with the particle size increased. The MIE of sulfur dust with particle size over 150 μm was more than 13 J, therefore, it was hard to explode. The particle size should be controlled over 150 μm in the process of production.

(4) The MIE and the MIT-C of sulfur dust increased, as the water content increased. The MIE was greater than 10 mJ while the content was more than 4%, and the ignition risk of electrostatic and mechanical spark was low.

(5) The P_{max} and the R_{max} of sulfur dust rose at first and went down latter as the dust concentration increased, which both increased rapidly when the dust concentration was during 200-300 g/m^3 . The dust concentration should be controlled less than 200 g/m^3 in the process of production.

References

- [1] Hughes, R. I., Morgan, T. D. B., & Wilson, R. W. (1974) Is Pyrophoric Iron Sulfide a Possible Source of Ignition. *Nature* 248(5450), 670.
- [2] Haces, C., Corvo, F., & Reyes, A.P. (1981) Study of Corrosion Products Forming on Carbon Steels in a Humid Tropical Climate, Part 1. *Rev.Cienc.Quim.* 12(1), 55-65.
- [3] Zhang, S. Z. (1988) Basic principle of explosion. Beijing: National Defence Industrial Press.
- [4] Gracia, M., Gancedo, J. R., Barrero, M. L., Gracia, A. B., Martinez-Alonso, A., & Tascon, J. M. D. (1993) Comparative Moessbauer study of the effects of natural weathering and artificial oxidation on iron minerals present in coal. *Nucl.Instrum.Methods Phys.Res.,Sect.B*, B76(1-4), 191-194.
- [5] Pang, Q. Z., & Huang, Q. G. (1994) Dust explosion and prevention. *Labour Protection Science and Technology*, 14(1), 40-42.
- [6] Zhao, H. Y. (1996) Explosion principle of gas and dust. Beijing: Beijing Institute of Technology Press.
- [7] Going, J. E., Chatrathi, K., & Cashdollar, K. L. (2000) Flammability limit measurements for dusts in 20-L and 1- m^3 vessels. *Journal of Loss Prevention in the Process Industries*, 13, 209-219.
- [8] Zhang, C. G., & Jiang, J. C. (2005) Preliminary Study on the Dust Explosion Factors and Precautions. *Coal Chemical Industry*, 117(2), 8-11.
- [9] Cassel, H. M., & Liebman, I. (1959) The cooperative mechanism in the ignition of dust dispersions. *Combust Flame*, 3, 467-475.
- [10] Du, X., & Annamalai, K. (1994) The transient ignition of isolated coal particles. *Combust Flame*, 97, 339-354.
- [11] Chen, Y. H., Wang, X. D., & Huang, J. M. (2010) Risk analysis and prevention technology of the storage and transportation of bulk sulfur. *Petroleum Safety and Environmental Protection Technology*, 26(2), 15-17.
- [12] Bandyopadhyay, S., & Bhaduri, D.B. (1972) Prediction of ignition temperature of a single coal particle. *Combust Flame*, 18, 411-415.
- [13] Cassel, H. M., & Liebman, I. (1959) The cooperative mechanism in the ignition of dust dispersions. *Combust Flame*, 3, 467-475.
- [14] Amyotte, P. R., Soundararajan, R., & Pegg M. J. (2003) An investigation of iron sulphide dust minimum ignition temperatures. *Journal of Hazardous Materials*, A97, 1-9.
- [15] Eckhoff, R. K., & Randeberg, E. (2007) Electrostatic spark ignition of sensitive dust clouds of $\text{MIE}<1\text{MJ}$. *Journal of Loss Prevention in the Process Industries*, 20, 396-401.
- [16] Essenhigh, R. H., Misra, M. K., & Shaw, D. W. (1989) Ignition of coal particles: a review. *Combust Flame*, 77, 3-30.
- [17] Lu, D. C. (2010) Factor analysis and prevention of flammable dust explosion. *Fire Technique and Products Information*, 7, 57-61.